

Distribution Box Instruction

1. Description:

The equipment is used as a termination point for the feeder cable to connect with drop cable in FTTx communication network system. The fiber splicing, splitting, distribution can be done in this box, and meanwhile it provides solid protection and management for the FTTx network building.

2. Features:

- 1). Total enclosed structure, be in nice shape.
- 2). Material: PC+ABS, wet-proof, water-proof, dust-proof, anti-aging, protection level up to IP65.
- 3). Clamping for feeder cable and drop cable, fiber splicing, fixation, storage, distribution...etc all in one.
- 4). Cable, pigtails, patch cords are running through own path without disturbing each other, cassette type SC adapter installation, easy maintenance.
- 5). Distribution panel can be flipped up, feeder cable can be placed in a cup-joint way, easy for maintenance and installation.

3. Specification:

1). Environmental Requirement

Working temperature: $-40^{\circ}\text{C} \sim +85^{\circ}\text{C}$

Relative humidity: $\leq 85\%$ ($+30^{\circ}\text{C}$)

Atmospheric pressure: $70\text{KPa} \sim 106\text{Kpa}$

2). Main Technical Data

Insertion loss: $\leq 0.2\text{dB}$

UPC return loss: $\geq 50\text{dB}$

APC return loss: $\geq 60\text{dB}$

Life of insertion and extraction: > 1000 times

3). Thunder-proof Technical Data

The grounding device is isolated with the cabinet, isolation resistance is no less than $2 \times 10^4 \text{M}\Omega / 500\text{V}(\text{DC})$; $IR \geq 2 \times 10^4 \text{M}\Omega / 500\text{V}$

The withstand voltage between grounding device and cabinet is no less than $3000\text{V}(\text{DC})$ /min, no puncture, no flashover; $U \geq 3000\text{V}$



4. Configuration table:

Model	Size (Pic 1)	Max Capacity			Installation Size
	A*B*C(mm)	SC	LC	PLC	D (mm)
CNT-4A	186*116*40	4	8	8(LC)	195

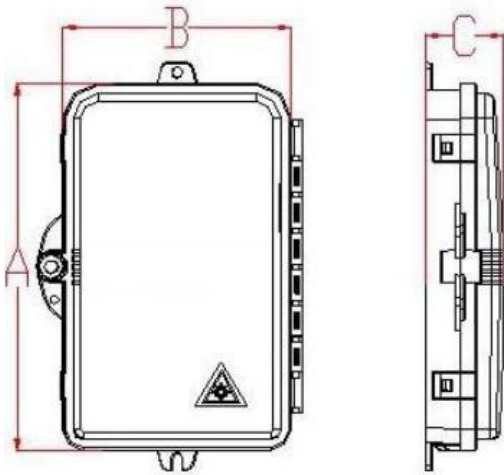

Pic 1 Box Size

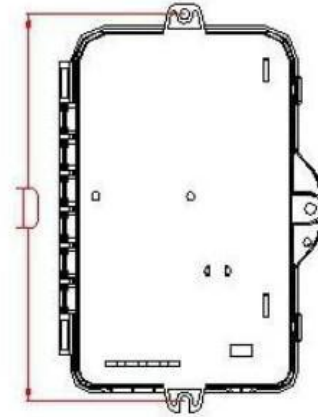

Pic 2 Installation Size

5. Product cable ways:

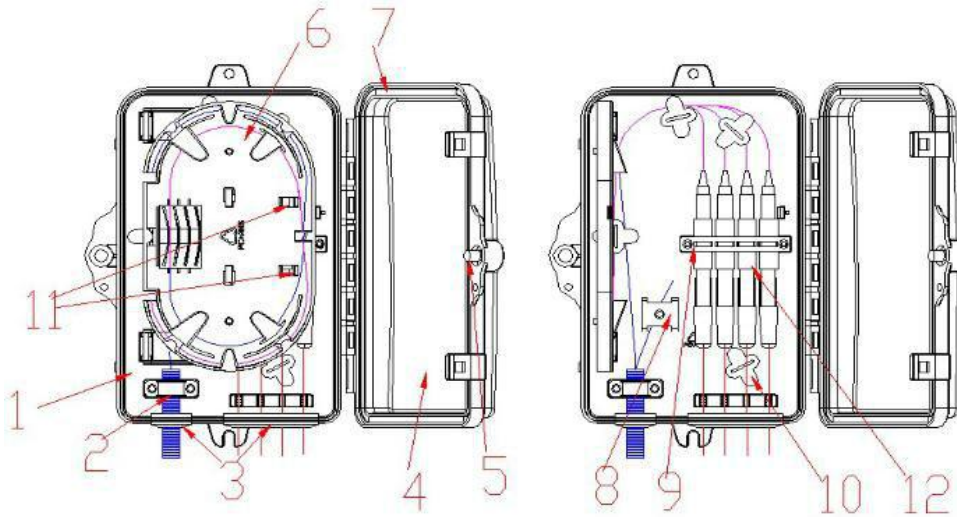

1. Base; 2. Main cable mound layer; 3. water-proof rubber tube; 4. Lid; 5. Lock;
 6. Splicing flap plate; 7. Seal gasket; 8. Main cable strengthen mound layer; 9. Adaptor holder;
 10. Pigtail bar; 11. PLC Mounting position; 12. Adaptor